

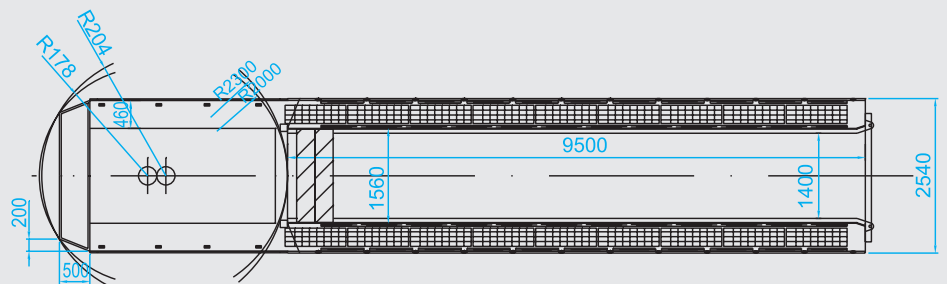

Semirimorchio a 3 assi come caricatore interno per il trasporto di elementi prefabbricati in calcestruzzo, travi e leganti

- Costruzione telaio saldato in acciaio
- Sospensione a ruote indipendenti con compensazione idraulica dell'assale e dispositivo di sollevamento e abbassamento
- Dispositivo di sollevamento per ogni ruota
- Piattaforma frontale con vano portaoggetti
- Letto di carico profondo
- Sistema di fissaggio del carico idraulico
- La parete posteriore può essere ruotata di circa 270 gradi
- Anelli fermacarico di ognuno da 3 tonn e 8 tonn forza tirante
- Rivestimento laterale chiuso, rimovibile
- Vano portaoggetti
- Segnaletica di pericolo estensibile
- Opzioni:
 - ▷ Bloccaggio palett idraulico
 - ▷ Piano di carico inseribile con aggregato eletroidraulico per carico pelett e colletame
 - ▷ Aggregato eletroidraulico
 - ▷ Sistema di lubrificazione centrale
 - ▷ Zincatura a spruzzo

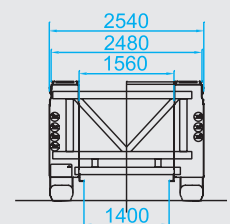
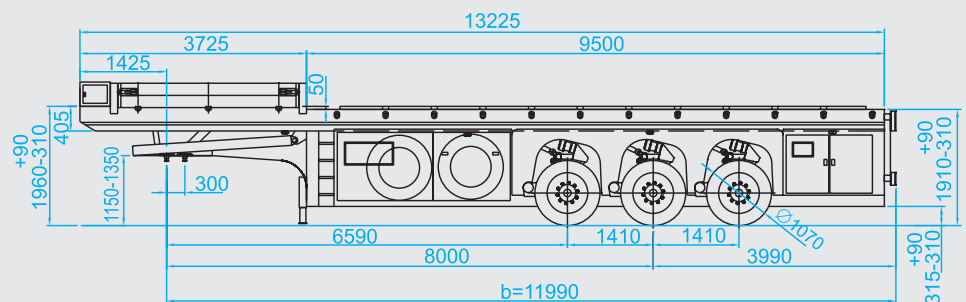

Meusburger Fahrzeugbau GmbH

Kollmering 7
D-94535 Eging am See
Tel. +49 (0) 85 44/96 22-0
Fax +49 (0) 85 44/96 22 50
info@meusburger.ch
www.meusburger.ch

FTS Altstätten AG

Mühlbachstraße 9
CH-9450 Altstätten
Tel. +41 (0) 71/757 07 57
Fax +41 (0) 71/757 07 67
infos@meusburger.ch
www.meusburger.ch

Meusburger NOVTRUCK ZAO NOVTRUCK

Magistralnaiya Straße 15
RU-173008 Velikiy Novgorod
Tel. +7 (8162) 944 011
Fax +7 (8162) 944 009
info@meusburger-ru.ru
www.meusburger-ru.ru

Peso totale:	45 000 kg
Portata ralla:	18 000 kg
Portata assi:	27 000 kg
Tara:	10 500 kg
Portata:	34 500 kg